

(4) Mounting Holes for M5 [#10] Screws.
See Detail A for top mounting hole dimensions.

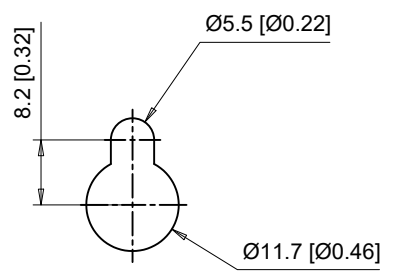

Detail A
Top mounting hole dimensions
Scale 1:1

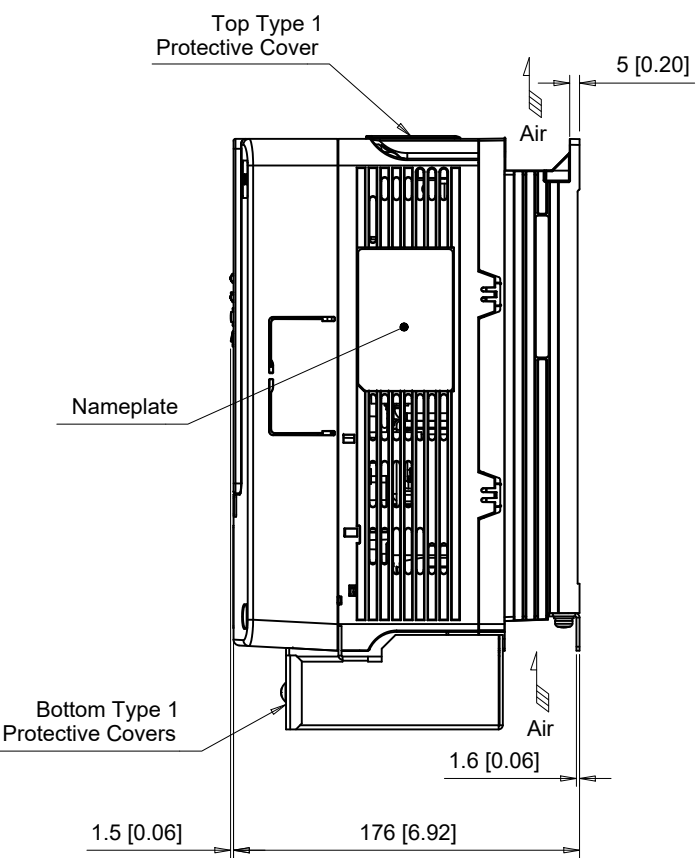
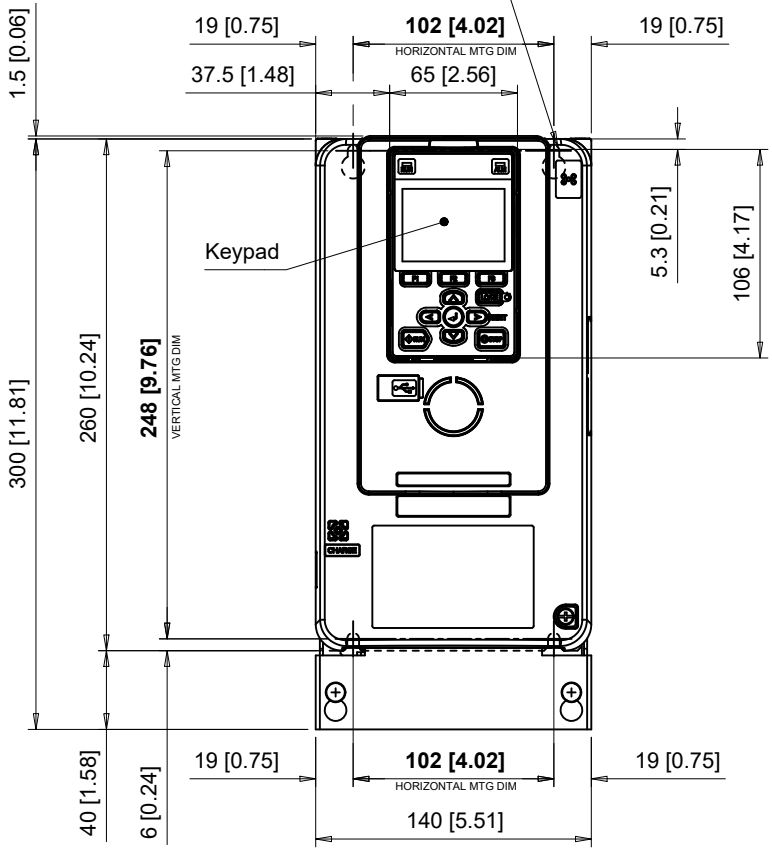
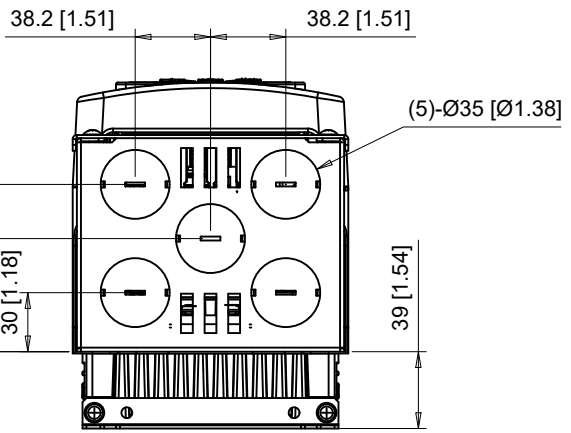

The dimensions shown are for an IP20 Type Drive that has been converted to a NEMA Type 1 Drive by adding the parts from NEMA 1 Kit part number 900-192-121-001

C/C: GA80□	INPUT VOLTAGE 3-PHASE (VAC)	WEIGHT Kg (lb)	COOLING FANS
2004□□□	200 TO 240	4.1 (9.0)	0
2006□□□		4.1 (9.0)	0
2008□□□		4.1 (9.0)	0
2010□□□		4.1 (9.0)	0
2012□□□		4.1 (9.0)	0
4002□□□	380 TO 480	4.1 (9.0)	0
4004□□□		4.1 (9.0)	0
4005□□□		4.1 (9.0)	0

□ denotes A-Z

1	REVISED KIT PART NUMBER
0	INITIAL RELEASE



	UNITS MM [IN]
	SCALE 1:4

DRWN.	J. MATTAS	6-28-18
CHKD.	J. PIOTROWSKI	7-9-18
TECH.	L. UDDIN	7-16-18
APRV.	J. CAIRO	8-21-18

TITLE	GA800 DIMENSION DRAWING FRAME SIZE 1 NEMA TYPE 1 ENCLOSURE
-------	--

SIZE	A	PAGE	1 OF 3
DWG.NO.	DD.GA80.FR1.N1		

REV	1
-----	---

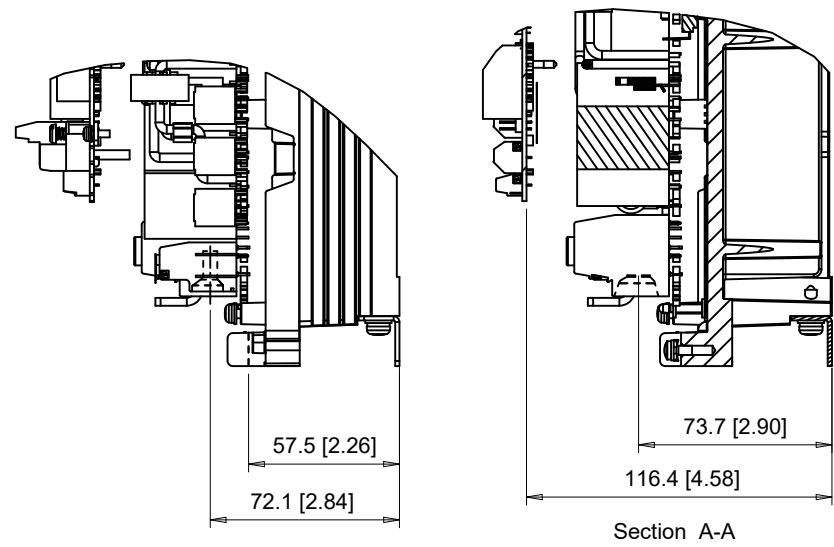
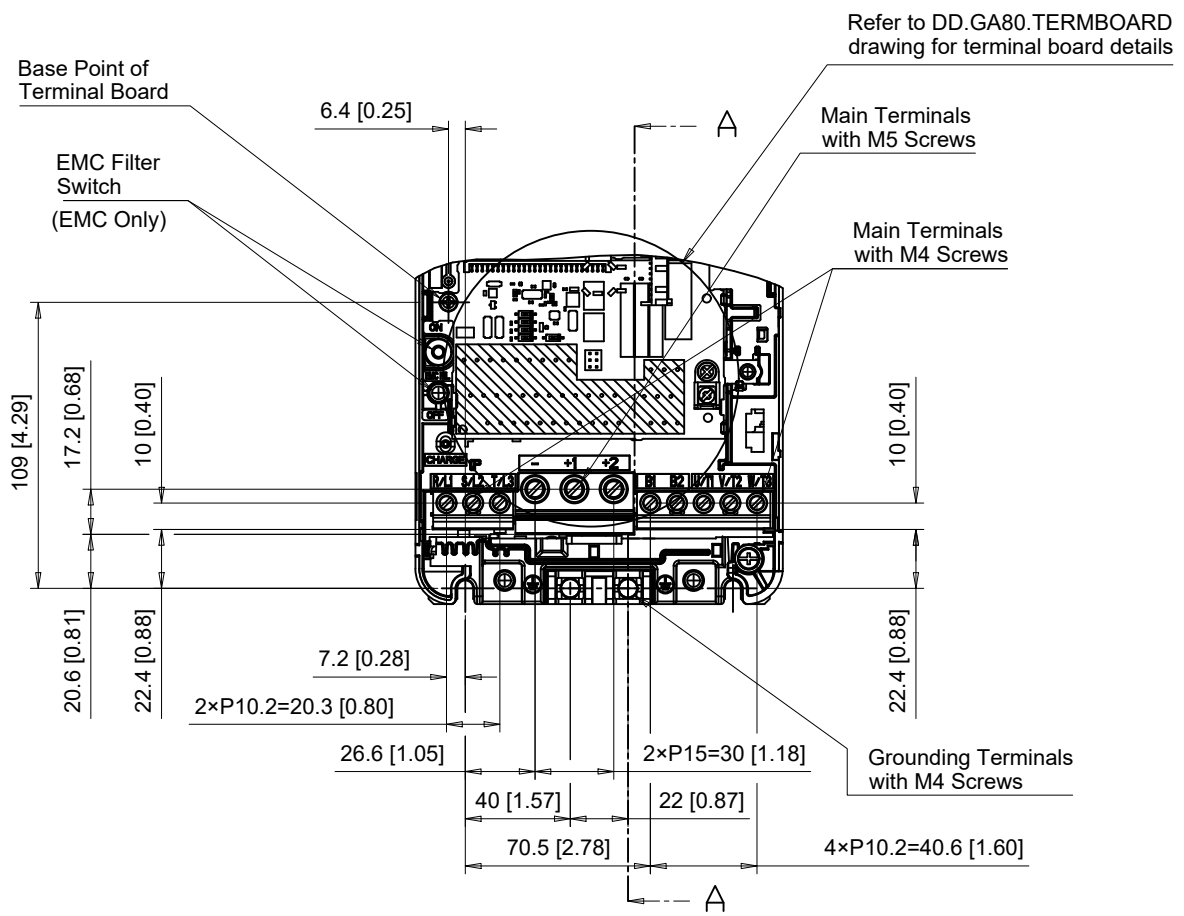

C/C: GA80□	TERMINAL SYMBOL	WIRE RANGE AWG (mm ²)	TERMINAL SCREW	CLAMPING TORQUE N.m. (lb.in.)
2004□□□	R/L1, S/L2, T/L3	14 - 6 (2.5 - 16)	M4	1.5 - 1.7 (13.5 - 15)
2006□□□	U/T1, V/T2, W/T3	14 - 6 (2.5 - 16)	M4	1.5 - 1.7 (13.5 - 15)
2008□□□	-, +1, +2	14 - 10 (2.5 - 4)	M5	2.3 - 2.5 (19.8 - 22)
2010□□□	B1, B2	14 - 6 (2.5 - 16)	M4	1.5 - 1.7 (13.5 - 15)
2012□□□	⊕	14 - 8 (2.5 - 10)	M4	1.2 - 1.5 (10.6 - 13.3)
4002□□□				
4004□□□				
4005□□□				

□ Denotes A-Z
 Note: Refer to applicable codes and standards for proper wire type and size.

1	REVISED KIT PART NUMBER
0	INITIAL RELEASE



UNITS MM [IN]
 SCALE 1:3

DRWN.	J. MATTAS	6-28-18
CHKD.	J. PIOTROWSKI	7-9-18
TECH.	L. UDDIN	7-16-18
APRV.	J. CAIRO	8-21-18

TITLE
 GA800 DIMENSION DRAWING
 FRAME SIZE 1
 NEMA TYPE 1 ENCLOSURE

SIZE A
 PAGE 2 OF 3
 DWG.NO.
 DD.GA80.FR1.N1

REV
 1

Minimum Installation Clearances

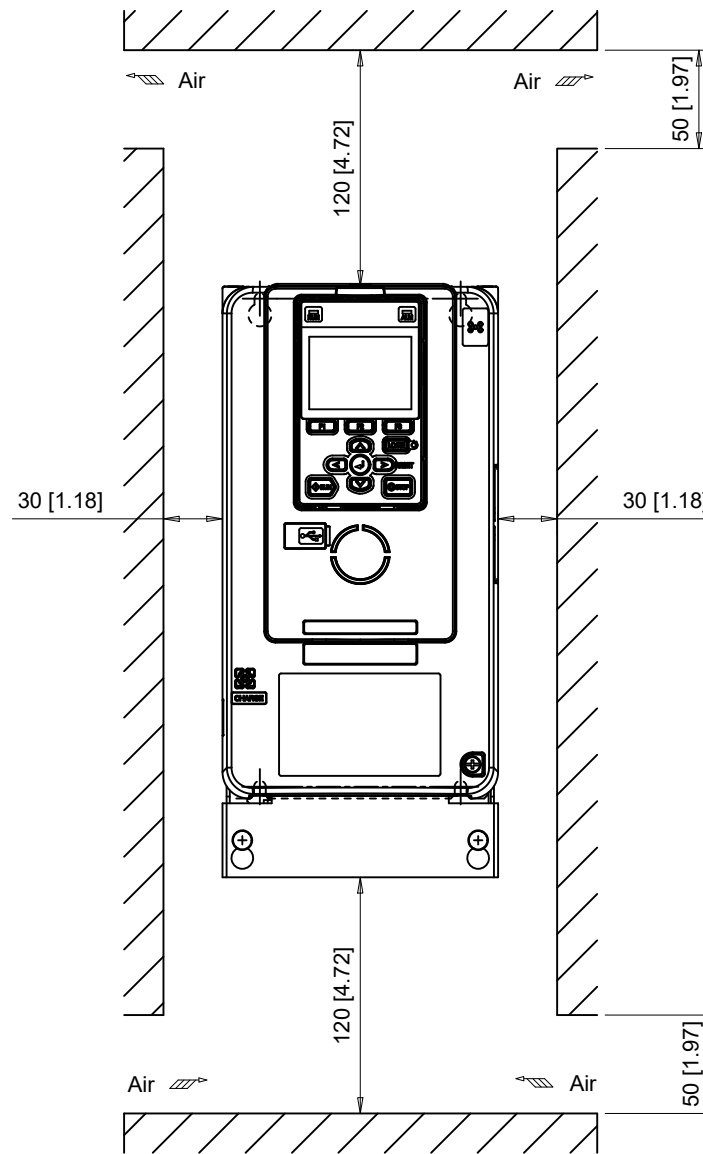

Note:
For alternate mounting configurations, consult manual.

1	REVISED KIT PART NUMBER
0	INITIAL RELEASE



	UNITS MM [IN]
	SCALE 1:4

DRWN.	J. MATTAS	6-28-18
CHKD.	J. PIOTROWSKI	7-9-18
TECH.	L. UDDIN	7-16-18
APRV.	J. CAIRO	8-21-18

TITLE	GA800 DIMENSION DRAWING FRAME SIZE 1 NEMA TYPE 1 ENCLOSURE
-------	--

SIZE	A	PAGE	3 OF 3
DWG.NO.	DD.GA80.FR1.N1		

REV	1
-----	---